



# Mono Frog Juicer v1.0

## Automated Frog Control For DCC

TamValleyDepot.com

Installation of the Mono Frog Juicer (MFJ) is simple. Connect the 3 pin terminal block to the DCC bus and the frog to be powered as shown in the diagram. The middle wire goes to the frog and the two outer wires go to the DCC bus. Place the board on a non-conducting surface (wood or wallboard). A piece of double-sided foam tape is ideal for affixing the board.

Track Bus Connection to Two Outer Wires

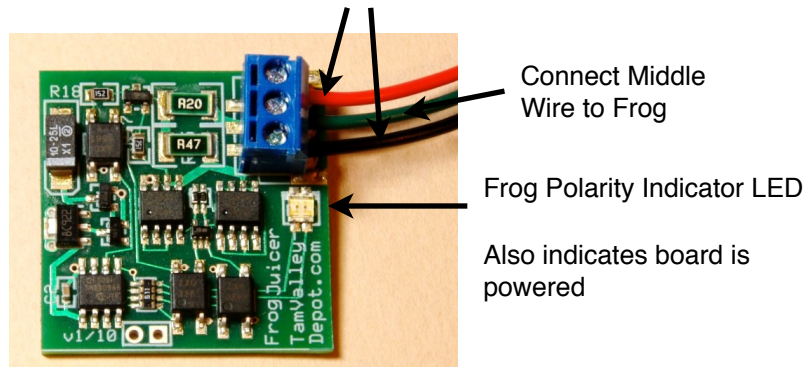

Use #22 - #26 ga. wire and keep the runs under 3 feet. The Frog Polarity Indicator LED will change color when a train crosses a frog that needs to be switched. There should be no interruption of sound or movement when this occurs (unless the track is dirty - sorry - the MFJ can't automatically fix this problem).

There should be no resistors or lamps between the booster and the DCC input. If there are, they will prevent the MFJ from switching properly. The solution is to run the wires directly to the booster.

Each Mono Frog Juicer draws just 17 mA of power from your DCC system.

## Troubleshooting

If the LEDs are not lit make sure the two outer wires are connected to DCC power and that the DCC power is on. The board will NOT work with DC.

If the LEDs both go off for a second and then come back on this indicates that the booster detected the short before the MFJ. If this happens repeatedly then something is wrong and it must be fixed or you risk destroying the MFJ.

- Make sure the frog is isolated from the track - a short between the frog and the rest of the track will prevent the board from working and must be resolved by fixing the short. Look to see if one of the gaps has closed or if a loose wire is touching the frog.
- Make sure there is no circuit breaker or light bulb between the input of the MFJ and the booster. If there is run the wires directly back to the DCC booster bypassing the circuit breaker or lightbulb.
- If you have styrene in the gaps around the frog to hold it open, make sure the styrene is not protruding above the height of the railheads. This will prevent the wheels from contacting both rails at once and prevent the momentary short needed to switch the frog juicer.
- In some cases it may be advantageous to place all the frogs on their own power section with their own booster. Tam Valley Depot sells a booster that is ideal for this.
- Check for more information at [www.tamvalleydepot.com/](http://www.tamvalleydepot.com/)

Technical Support may be obtained by emailing [dmcree@tamvalleyrr.com](mailto:dmcree@tamvalleyrr.com).



Suggested Wiring.

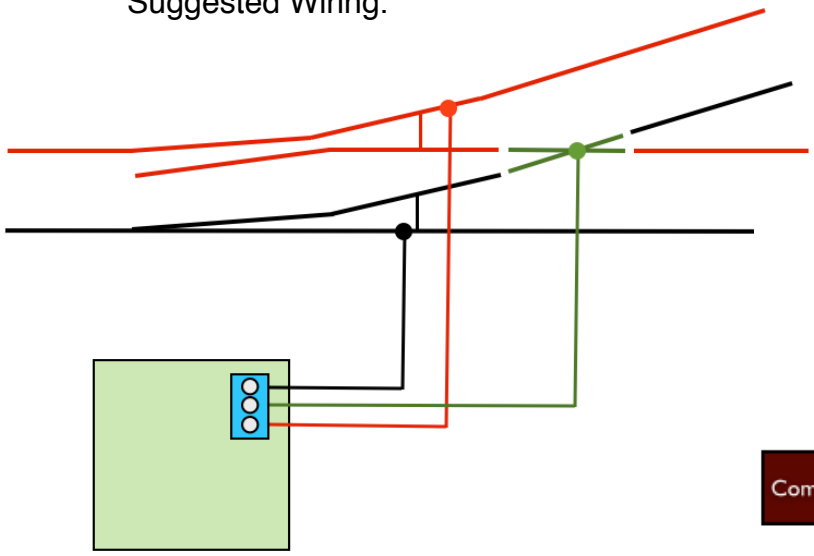

(May not work well if you are using Circuit Breakers)

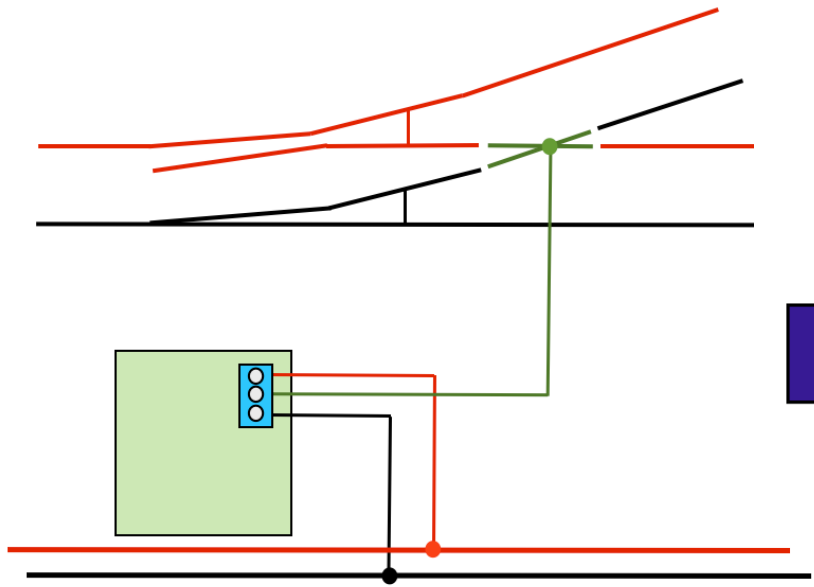

DCC Bus (Direct to command station with no Circuit Breaker between)

